

WATER MASTER™ VACUUM TANKERS



WATER MASTER

Developed by fire chief Reggie Ridgway, Water Master vacuum tankers are designed to be easy to use and safe to operate.

Featuring a unique self-filling vacuum system, Water Master vacuum tankers can be filled at up to 2000 gallons per minute without a Class A pumper. The tankers can self-fill from up to three suction inlets using almost any alternative water source including ponds, rivers, lakes, ditches and swimming pools. The units feature baffled aluminum tanks holding up to 4000 gallons of water and come standard with a 460 cubic feet per minute vacuum pump, allowing one operator to deliver more than 250 gallons per minute in a three mile shuttle.

Water Master vacuum tankers were designed from the ground up to deliver the maximum amount of water to the scene with the minimum amount of personnel.



When lives are in the balance and seconds count

WATER MASTER VACUUM TANKERS

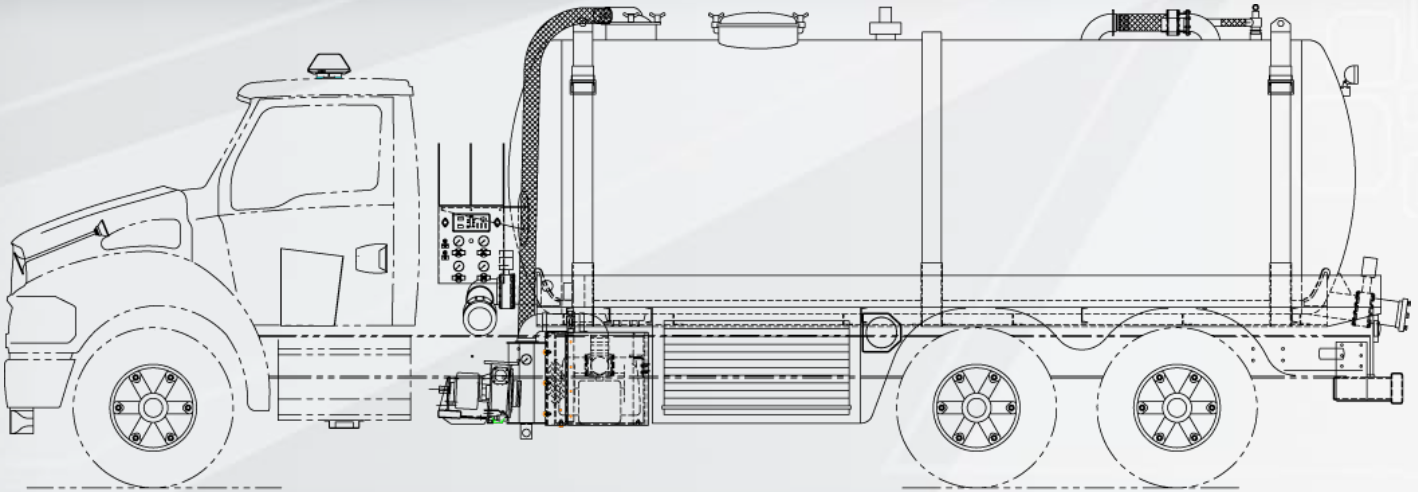

STANDARD

- Various chassis options include: International® and Freightliner®
- Allison® 3000EVS six speed automatic
- 3500 gallon aluminum vacuum tank
- Moro 460 CFM vacuum pump
- NFPA LED lighting package
- Adapters and six-inch barrel strainer
- 36' of suction hose
- 3500 gallon portable folding tank
- Closed circuit monitor with two cameras
- Electronic engine and pump pressure controls
- Lifetime tank warranty

OPTIONAL

- 500, 750, and 1000 GPM PTO pumps
- 2000 to 4000 gallon baffled aluminum tanks
- Crosslay hose trays
- Front, side or rear 2.5" outlets
- Booster hose reel
- Extension and roof ladders
- SCBA storage compartments in wheel wells
- Onboard battery charger and air compressor
- SCBA storage compartment



For a dealer nearest you contact us at www.e-one.com or call 352.237.1122.

©2009 E-ONE, Inc. 904-10-301



When lives are in the balance and seconds count