



COMMERCIAL PUMPER



Up to 10 cu. ft. of additional compartment storage allows for multiple compartment configurations.



Optional drop-down or overhead ladder storage places ladders and equipment easily accessible at ground level.

COMMERCIAL PUMPER

When your department needs an apparatus and the budget is limited, the E-ONE Tradition Commercial Pumper is the unit that fits the bill.

The E-ONE Tradition Commercial Pumper is available on a two- or four-door chassis, optional seating for up to six personnel and offers an extended front bumper for hose and preconnect storage.

The body is designed with flexible ladder and equipment storage options, up to twelve body compartment configurations and side- or top-mount pump panel operations. This body puts the equipment where you need it.

The E-ONE Tradition Commercial Pumper is practical, easily adaptable and, above all, economical.

- Commercial Chassis
- Hale® pump (1250 or 1500)
- 89- or 129-cu. ft. of NFPA hosebed storage
- Three officer-side ladder / equipment storage options
- Side-mount or top-mount pump panel
- Spacious body compartments for storage of NFPA equipment
- Optional extended enhanced body provides increased cu. ft. of storage
- 750- or 1000-gal water tanks



* Specifications subject to change without notice or obligation. Options vary by dealer. E-ONE is ISO 9001:2000 compliant.



COMMERCIAL PUMPER

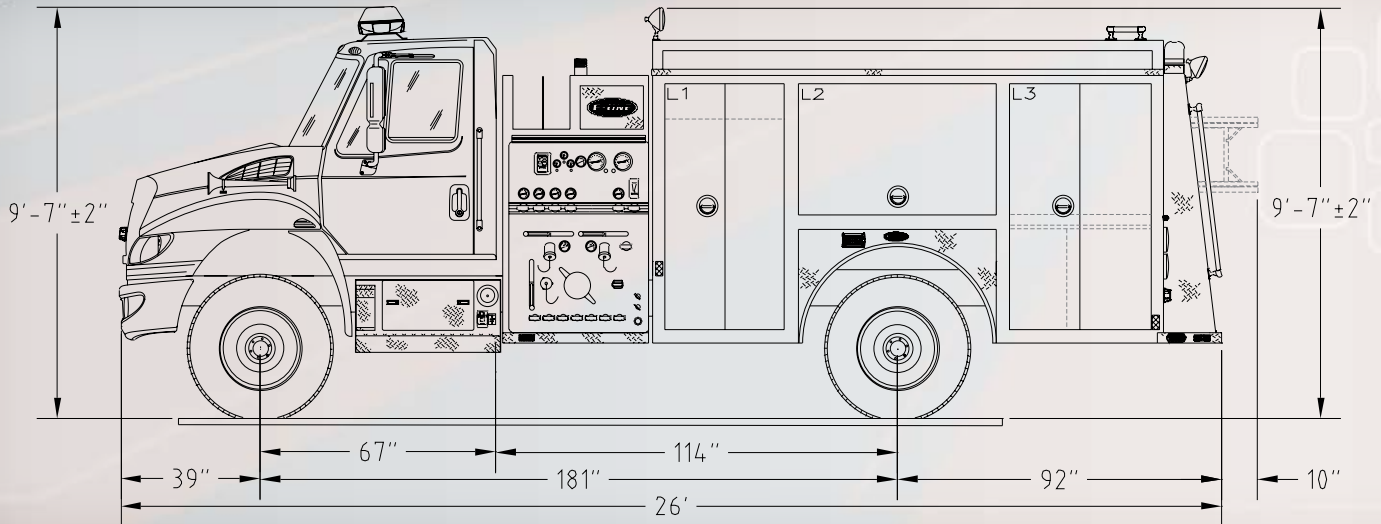

CHASSIS FEATURES

- Freightliner® M2 2- and 4-door cab
- Mercedes® 300-HP engine (includes auxiliary brake with 38000 lbs.-GVW)
- Air conditioning
- EVS3000 transmission with touch-button shifter
- Chrome front bumper
- Seating for 3 to 2 crew personnel

CHASSIS OPTIONS

- International® 2- and 4-door cab
- International 310- or 330-HP engines (includes auxiliary brake with 38000 lbs.-GVW)
- Mercedes 330 or 350 or Cummins 300 or 330 (all with auxiliary braking)*
- Aluminum wheels
- 20" bumper extension with center-mounted storage tray
- Deluxe chassis trim package
- Two-tone cab paint

BODY FEATURES

- Full-height driver-side compartmentation with rescue style openings
- Half-side with adjustable ladder storage brackets
- Full-height rear-body compartmentation with roll-up door

- Painted hinged side compartment doors
- 1000-gallon polypropylene water tank with lifetime warranty
- 89 cu. ft. of hosebed storage

BODY OPTIONS

- (3) driver-side compartment configurations
- (9) officer-side compartment configurations
- (3) ladder equipment storage configurations
- (3) compartment rear-body configurations for use with rear dump
- Roll-up side compartment doors
- 750-gallon polypropylene water tank with lifetime warranty
- 129 cu. ft. of hosebed storage (750-gallon water tank)
- 30-gallon integral foam cell
- Wheel well SCBA bottle storage
- Body and pump module rubrails

PLUMBING & PUMP MODULE FEATURES

- Hale 1250-GPM pump. Includes (4) 2.5" and (1) 3" discharge
- Side-mount control panel
- (2) 1.5" crosslay discharges
- Vertically hinged stainless steel pump access doors

PLUMBING & PUMP MODULE OPTIONS

- Hale 1500-GPM pump. Includes (3) 2.5" and (2) 3" discharges
- Top-mount control panel
- Top-mount walkway storage compartments
- (2) 1.5" crosslays or speedlays
- Running board suction hose storage tray(s)
- 2.5" auxiliary rear tank fill with gauge
- 5" auxiliary rear-pump intake
- 1.5" top- or rear-mounted booster reel with 200' of 1" hose
- 1.5" front bumper discharge
- Rear dump
- Foam system

ELECTRICAL FEATURES

- Federal incandescent upper-level and LED lower-level NFPA warning lighting
- Federal siren with speaker

ELECTRICAL OPTIONS

- Federal LED cab-mounted lightbar
- Federal Night Fighter lights
- Diesel generator package
- Electrical cord reel

* Engines are subject to availability



A corrosion-resistant polypropylene tank is the best choice for long life and features a lifetime warranty. They are cradled in a floating mount system to reduce tank stress and extend service life. Integral single and dual foam cells are popular options.



The knurled edge of our rub rails reduces the chance of injury by providing a slip-resistant stepping surface in addition to our Gator Grip™ step areas.



Rear compartments are transverse for increased overall access and storage.



For a dealer nearest you contact us at www.e-one.com or call 352.237.1122.

A Subsidiary of Federal Signal Corporation.
©2007 E-ONE, Inc. 701-06-305

WHEN LIVES ARE IN THE BALANCE AND SECONDS COUNT